



US008736163B2

(12) **United States Patent**
Kim et al.

(10) **Patent No.:** **US 8,736,163 B2**
(45) **Date of Patent:** **May 27, 2014**

(54) **ORGANIC ELECTRO-LUMINESCENCE DISPLAY DEVICE AND METHOD FOR FABRICATING THE SAME**

(56) **References Cited**

U.S. PATENT DOCUMENTS

4,547,456 A *	10/1985	Kojima et al.	430/330
4,654,965 A *	4/1987	Uehara et al.	29/830
6,737,176 B1 *	5/2004	Otsuki et al.	428/690
6,744,197 B2 *	6/2004	Park et al.	313/504
6,784,612 B2 *	8/2004	Park et al.	313/512
2002/0021089 A1 *	2/2002	Kim	313/506
2003/0168966 A1 *	9/2003	Kobayashi et al.	313/495
2003/0170493 A1 *	9/2003	Chen et al.	428/690
2004/0051445 A1 *	3/2004	Adachi	313/504
2004/0090170 A1	5/2004	Cha et al.	
2004/0135496 A1 *	7/2004	Park et al.	313/504

(Continued)

FOREIGN PATENT DOCUMENTS

CN	1446032 A	10/2003
CN	1472992 A	2/2004

(Continued)

OTHER PUBLICATIONS

Office Action issued in corresponding German Patent Application No. 10 2007 034 773.3-53; issued Oct. 31, 2008.

(Continued)

Primary Examiner — Karabi Guharay

(74) *Attorney, Agent, or Firm* — Brinks Gilson & Lione

(57) **ABSTRACT**

An organic electro-luminescence display device and a method for fabricating the same are provided. A first substrate and a second substrate are sealed by a sealant. An organic electro-luminescent diode is formed on the first substrate. The sealant contains a frit glass and a light-heat converter. The frit glass can reduce the moisture and oxygen transmission rate by preventing the organic electro-luminescent diode from being thermally decomposed during a curing process. Since the two substrates are encapsulated by the frit glass, the lifetime and reliability of the organic electro-luminescence display device can be increased.

10 Claims, 10 Drawing Sheets

(75) Inventors: **Jeong Hyun Kim**, Gyeonggi-do (KR);
Choong Keun Yoo, Gyeonggi-do (KR);
Heung Lyul Cho, Gyeonggi-do (KR);
Joon Suk Lee, Seoul (KR); **Jong Seok Moon**, Seoul (KR); **In Sun Yoo**, Incheon (KR)

(73) Assignee: **LG Display Co., Ltd.**, Seoul (KR)

(*) Notice: Subject to any disclaimer, the term of this patent is extended or adjusted under 35 U.S.C. 154(b) by 703 days.

(21) Appl. No.: **11/824,001**

(22) Filed: **Jun. 28, 2007**

(65) **Prior Publication Data**

US 2008/0001533 A1 Jan. 3, 2008

(30) **Foreign Application Priority Data**

Jun. 30, 2006 (KR) 10-2006-0061211

(51) **Int. Cl.**
H01L 51/52 (2006.01)
H01L 51/56 (2006.01)

(52) **U.S. Cl.**
USPC 313/512; 445/25

(58) **Field of Classification Search**
CPC H01L 51/524; H01L 51/5246; H01L 27/3251

USPC 313/512, 504; 257/100; 445/25
See application file for complete search history.

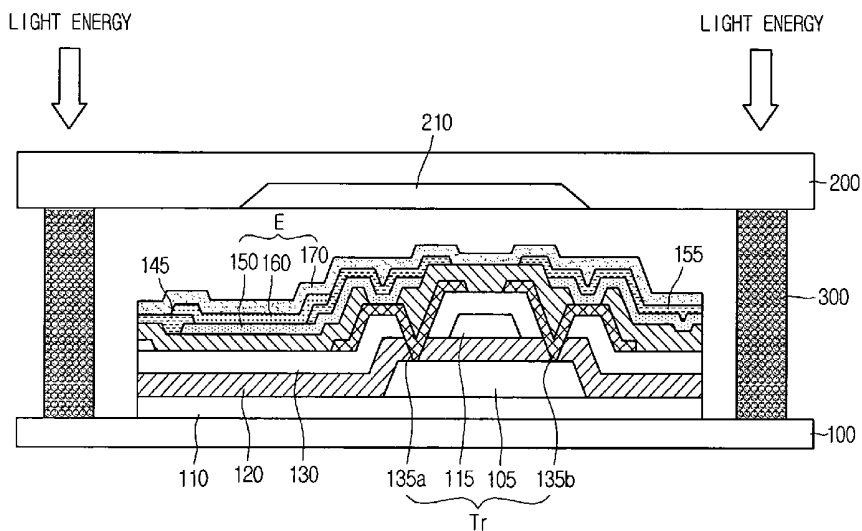

(56)

References Cited

U.S. PATENT DOCUMENTS

2004/0201348 A1* 10/2004 Anandan 313/512
2005/0001545 A1 1/2005 Aitken
2005/0099114 A1* 5/2005 Wu et al. 313/504
2007/0045517 A1* 3/2007 Fukuyoshi et al. 250/208.1

FOREIGN PATENT DOCUMENTS

CN 1678138 A 10/2005
JP 08-083579 3/1996

KR 1020060005369 A 1/2006
KR 1020060025317 A 3/2006
WO 2005/029394 A2 3/2005

OTHER PUBLICATIONS

Office Action issued in corresponding Chinese Patent Application No. 2007101110530; mailed Dec. 19, 2008.

Notice of Allowance issued in corresponding Korean Patent Application No. 10-2006-0061211, mailed Apr. 11, 2013, 6 pages.

* cited by examiner

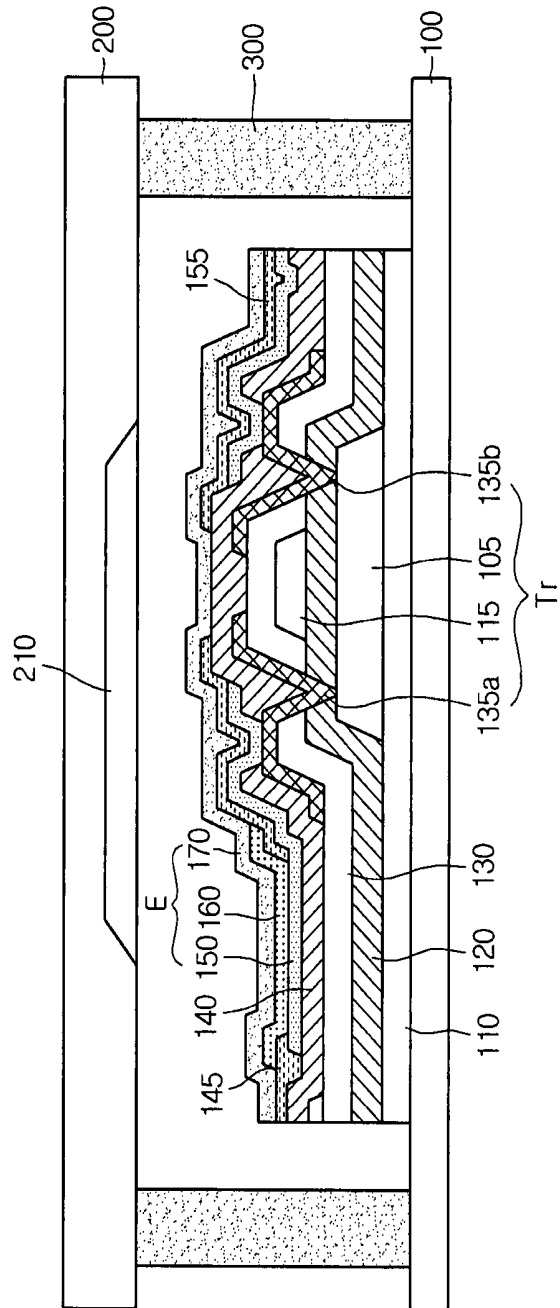

FIG. 1

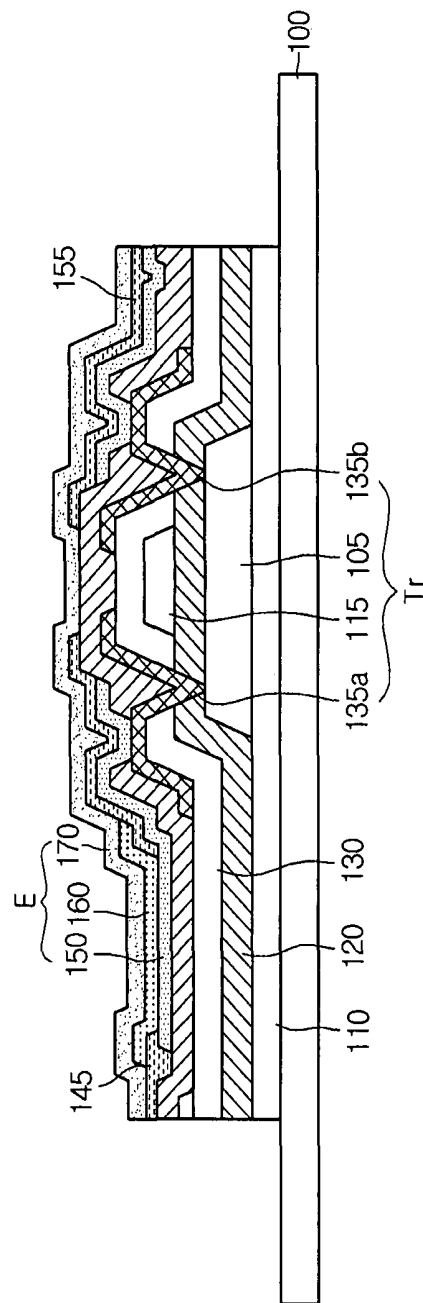

FIG. 2A

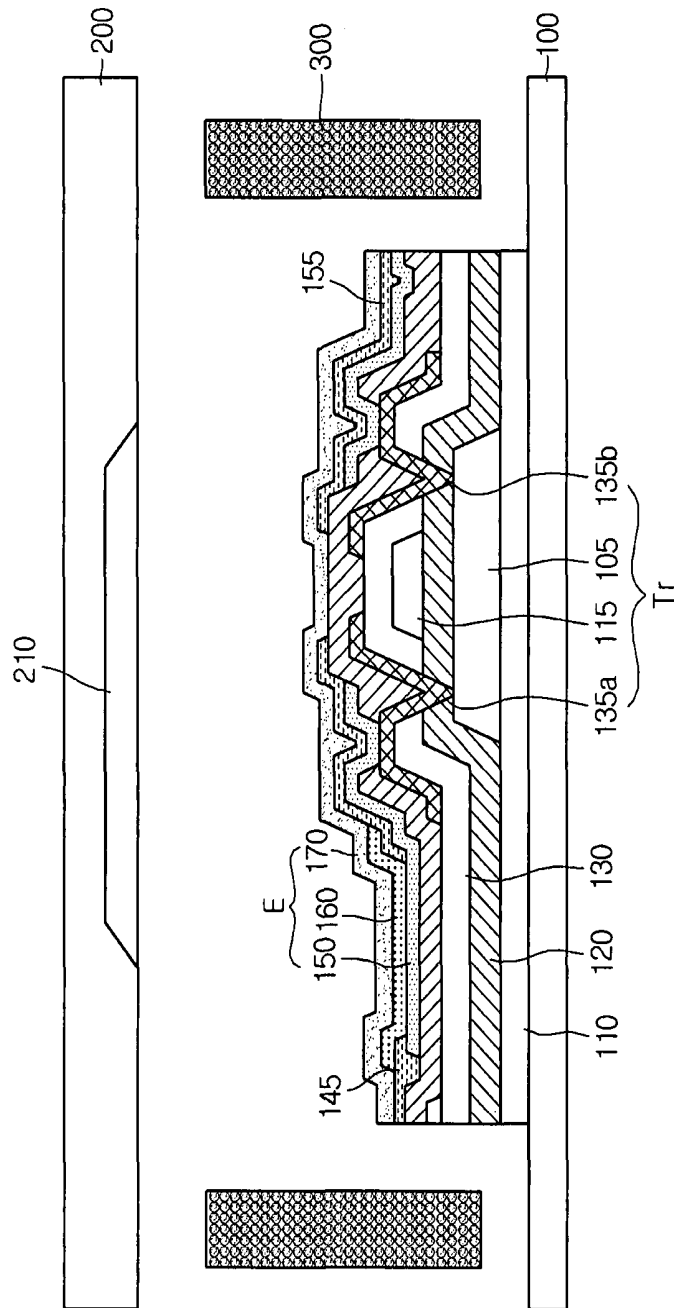

FIG. 2B

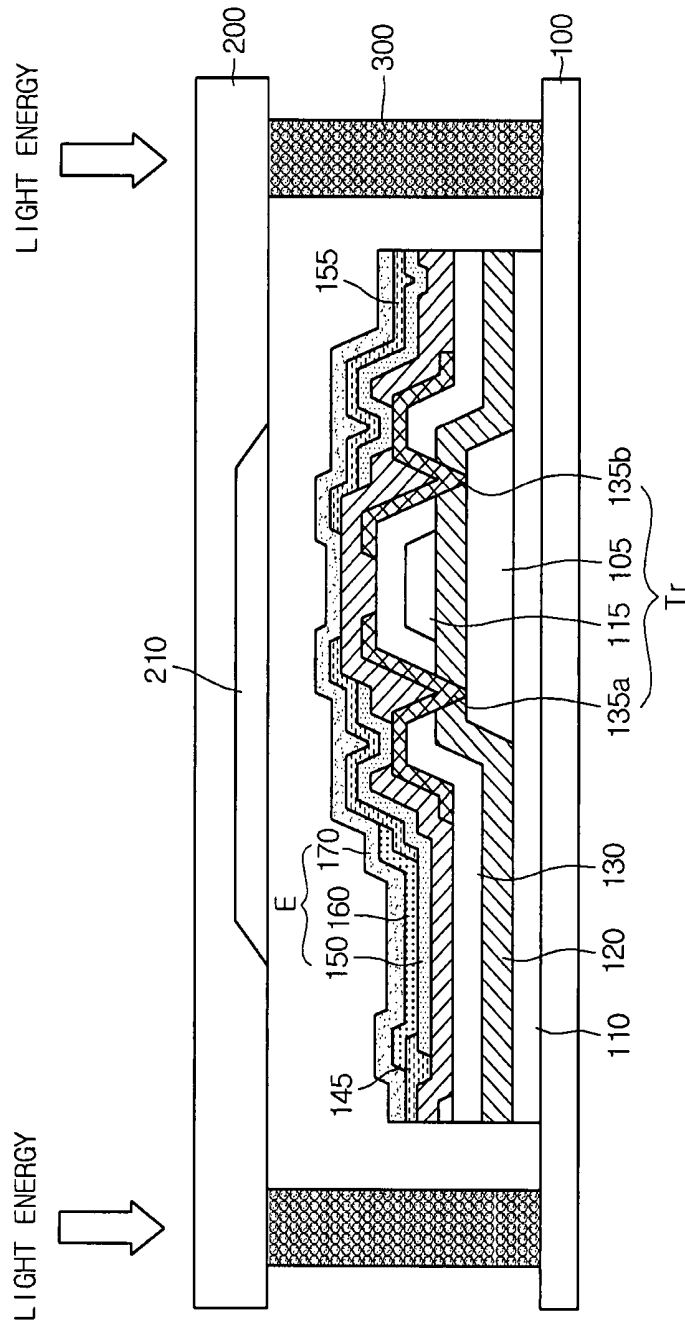

FIG. 2C

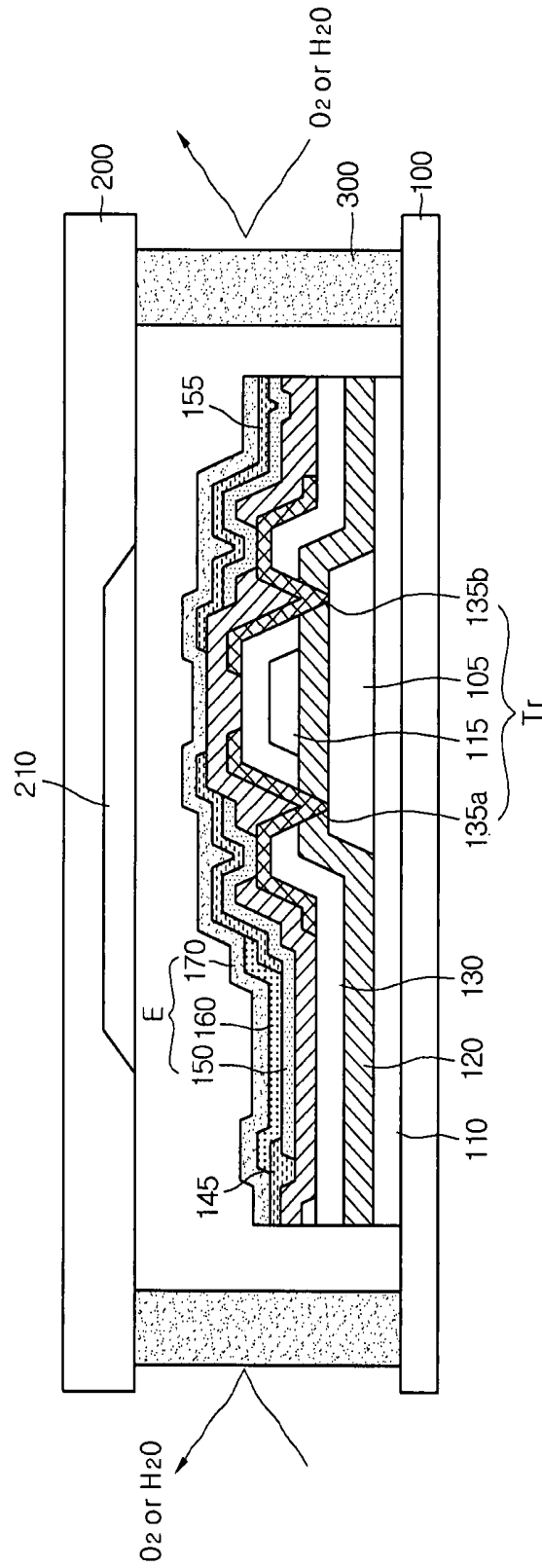

FIG. 2D

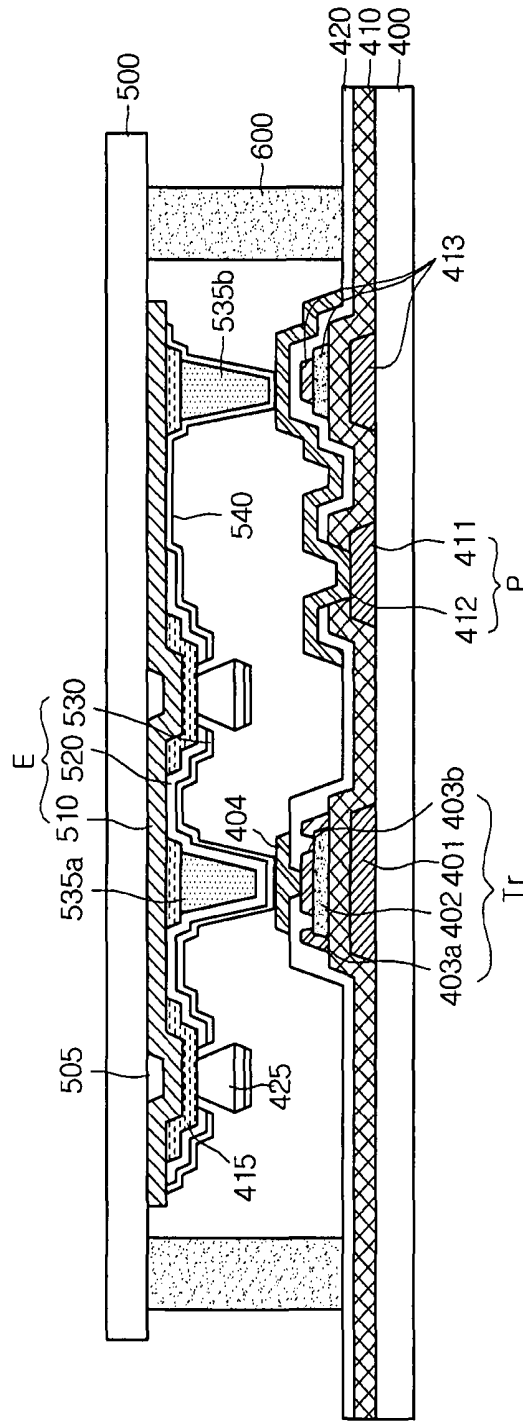

FIG. 3

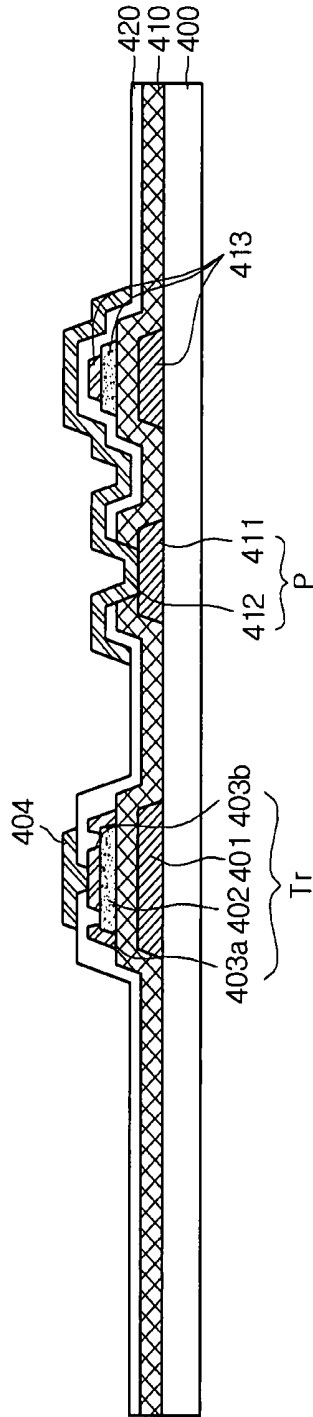

FIG. 4A

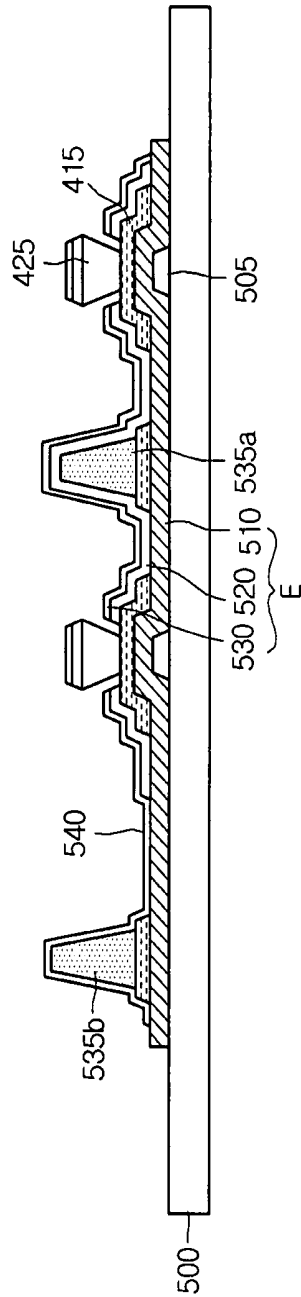

FIG. 4B

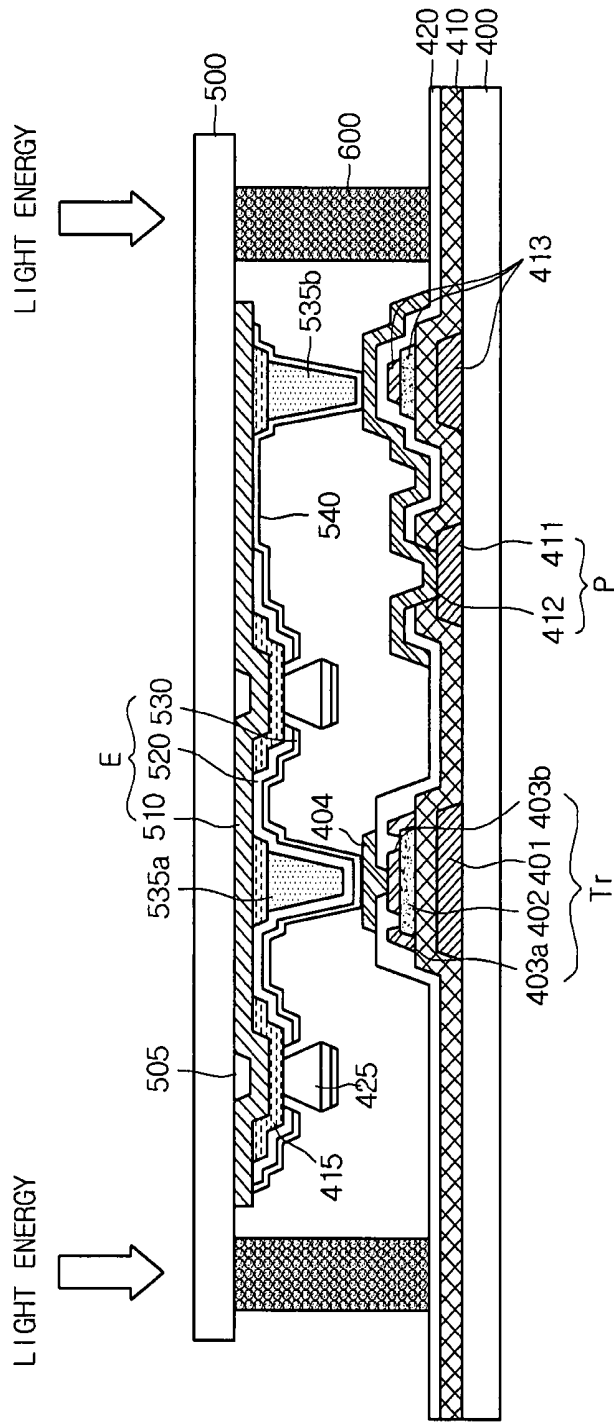

FIG. 4C

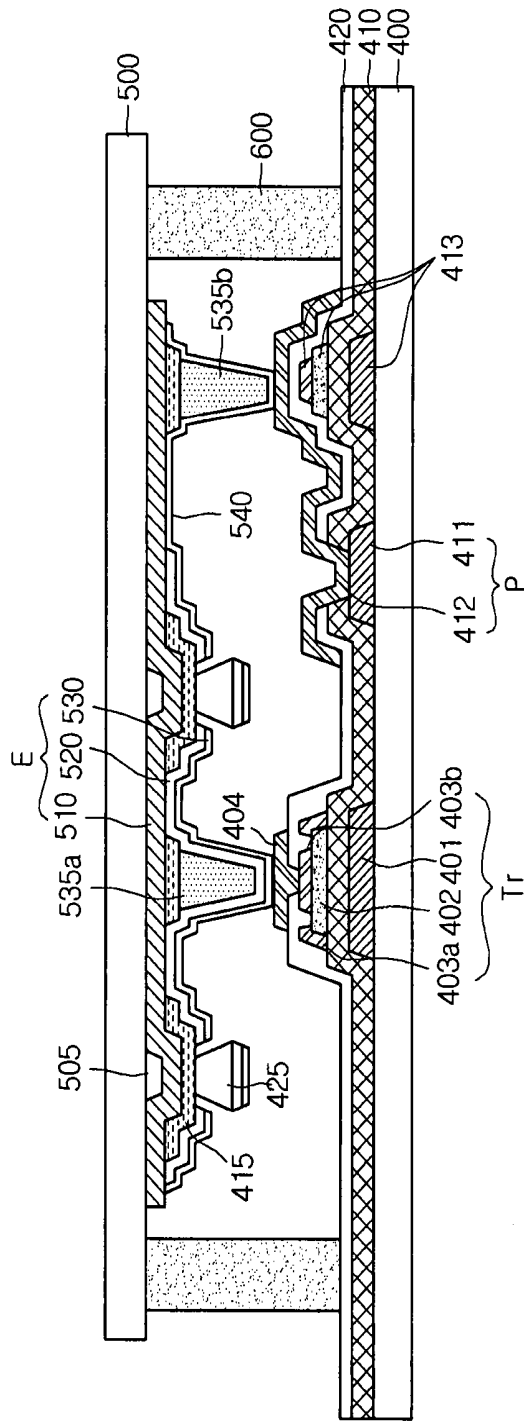

FIG. 4D

**ORGANIC ELECTRO-LUMINESCENCE
DISPLAY DEVICE AND METHOD FOR
FABRICATING THE SAME**

This application claims the benefit of Korean Patent Application No. 2006-0061211, filed on Jun. 30, 2006, which is hereby incorporated by reference as if fully set forth herein.

BACKGROUND OF THE INVENTION

1. Field of the Invention

The present invention relates to an organic electro-luminescence display device, and more particularly, to an organic electro-luminescence display device having an improved reliability and an extended lifetime, and a method for fabricating the same.

2. Description of the Related Art

Organic electro-luminescence display devices display an image using light generated by the recombination of electrons and holes in an organic emission layer. Unlike liquid crystal display devices (LCDs), the organic electro-luminescence display devices require no backlight assembly because they display an image using light generated from the organic emission layer. Therefore, the organic electro-luminescence display devices are lightweight and slim and have low power consumption, wide viewing angle, and high contrast ratio. In addition, the organic electro-luminescence display devices can be driven at a low DC voltage and have a rapid response time. Since all components of the organic electro-luminescence display devices are formed of solid materials, the organic electro-luminescence display devices are robust against external impact. Moreover, the organic electro-luminescence display device can be used in a wide temperature range and manufactured at a low cost.

Meanwhile, an organic emission layer of a conventional organic electro-luminescence display device is susceptible to moisture and oxygen. Therefore, the organic emission layer is sealed using a sealing member so as to protect it from moisture and oxygen. Due to the moisture and oxygen, the organic emission layer is degraded and thus dark spots occur therein. The occurrence of the dark spots will reduce the lifetime of the organic electro-luminescence display device and degrade its reliability.

The sealing member contains ultraviolet (UV) curable resin that is cured by irradiation of UV light. The UV curable resin is an organic-based material and cannot effectively block external moisture and oxygen. Consequently, the lifetime and reliability of the organic electro-luminescence display device are significantly reduced and degraded in high-temperature and high-humidity environment.

SUMMARY OF THE INVENTION

Accordingly, the present invention is directed to an organic electro-luminescence display device and a method for fabricating the same that substantially obviate one or more problems due to limitations and disadvantages of the related art.

An object of the present invention is to provide an organic electro-luminescence display device that can effectively block external moisture and oxygen, whereby the reliability and lifetime of the organic electro-luminescence display device can be increased.

Another object of the present invention is to provide a method for fabricating the organic electro-luminescence display device.

Additional advantages, objects, and features of the invention will be set forth in part in the description which follows

and in part will become apparent to those having ordinary skill in the art upon examination of the following or may be learned from practice of the invention. The objectives and other advantages of the invention may be realized and attained by the structure particularly pointed out in the written description and claims hereof as well as the appended drawings.

To achieve these objects and other advantages and in accordance with the purpose of the invention, as embodied and broadly described herein, there is provided an organic electro-luminescence display device including: a first substrate; a second substrate disposed to face the first substrate; a display element disposed on at least one of the first and second substrates; and a frit glass disposed between the first substrate and the second substrate to seal the display element, the frit glass being cured by a light-heat converter.

In another embodiment of the present invention, there is provided a method for fabricating an organic electro-luminescence display device, including: preparing a first substrate; forming a display element on the first substrate; preparing a second substrate; coating a sealant in a periphery of the first or second substrate, and attaching the first substrate to the second substrate; and curing the sealant, the sealant containing a powder-type frit glass and a light-heat converter.

It is to be understood that both the foregoing general description and the following detailed description of the present invention are exemplary and explanatory and are intended to provide further explanation of the invention as claimed.

BRIEF DESCRIPTION OF THE DRAWINGS

The accompanying drawings, which are included to provide a further understanding of the invention and are incorporated in and constitute a part of this application, illustrate embodiment(s) of the invention and together with the description serve to explain the principle of the invention. In the drawings:

FIG. 1 is a cross-sectional view of an organic electro-luminescence display device according to a first embodiment of the present invention;

FIGS. 2A to 2D are cross-sectional views illustrating a method for fabricating an organic electro-luminescence display device according to a first embodiment of the present invention;

FIG. 3 is a cross-sectional view of an organic electro-luminescence display device according to a second embodiment of the present invention; and

FIGS. 4A to 4D are cross-sectional views illustrating a method for fabricating a method for fabricating an organic electro-luminescence display device according to a second embodiment of the present invention.

DETAILED DESCRIPTION OF THE INVENTION

Reference will now be made in detail to the preferred embodiments of the present invention, examples of which are illustrated in the accompanying drawings. In the drawings, the thicknesses of layers and regions are exaggerated for clarity. Wherever possible, the same reference numbers will be used throughout the drawings to refer to the same or like parts.

FIG. 1 is a cross-sectional view of an organic electro-luminescence display device according to a first embodiment of the present invention.

Referring to FIG. 1, an organic electro-luminescence display device according to a first embodiment of the present invention includes a first substrate **100** and a second substrate **200**.

A TFT Tr and an organic electro-luminescent diode E are formed on a first substrate **100**. The organic electro-luminescent diode E is electrically connected to the TFT Tr.

A buffer layer **110** is formed on the first substrate **100**. A semiconductor layer **105** is formed on the buffer layer **110**. The semiconductor layer **105** may be formed of polysilicon. A gate insulating layer **120** is formed over the first substrate **100** on which the semiconductor layer **105** is formed. A gate electrode **115** is formed above a portion of the gate insulating layer **110** corresponding to the semiconductor layer **105**.

A source region and a drain region are defined in the semiconductor layer **105** by implanting impurities into the semiconductor layer **105** using the gate electrode **115** as a mask.

An interlayer insulating layer **130** is formed over the gate electrode **115** and the gate insulating layer **110**. Source/drain electrodes **135a** and **135b** is formed on the interlayer insulating layer **130** to electrically connect to the source/drain regions of the semiconductor layer **105** through the interlayer insulating layer **130** and the gate insulating layer. In this way, the TFT Tr is formed on the first substrate **100**.

A passivation layer **140** is formed over the first substrate **100** where the TFT Tr is formed, and an organic electro-luminescent diode E is formed on the passivation layer **140**. The organic electro-luminescent diode E is electrically connected to the TFT Tr. The TFT Tr is electrically connected to a power line **155**.

The organic electro-luminescent diode E includes a first electrode **150** electrically connected to the TFT Tr. The first electrode **150** may be formed by depositing a transparent conductive material and patterning the deposited transparent conductive material in each subpixel. The first electrode **150** may be formed of ITO or IZO.

Insulating layer patterns **145** having an opening exposing the subpixel are formed on the first electrode **150**. The insulating layer patterns **145** may be formed of photoresist resin.

An organic electro-luminescent diode E is formed in the first substrate **100**, and the second substrate **200** protects the organic electro-luminescent diode E from external moisture and oxygen. The second substrate **200** seals the organic electro-luminescent diode E.

A sealant **300** is formed in the periphery of the first substrate **100** or the second substrate **200**. The first substrate **100** and the second substrate **200** are attached to each other by the sealant **300**.

In this embodiment, the sealant **300** includes a frit glass cured using a light-heat converter. The frit glass effectively blocks external moisture and oxygen, thereby increasing the lifetime and reliability of the organic electro-luminescent diode E.

The light-heat converter converts light energy into heat energy.

Specifically, when light energy and heat are applied to the sealant containing the mixture of the powder-type frit glass and the light-heat converter, the light-heat converter converts the light energy into the heat energy and the converted heat energy is provided to the powder-type frit glass. Therefore, the time necessary to fabricate the frit glass can be reduced. In addition, the temperature necessary to fabricate the frit glass can be lowered.

The frit glass is fabricated by heating frit glass powder at more than about 400° C. and then cooling it. However, if the frit glass is fabricated at more than about 400° C., the organic

electro-luminescent diode E may be thermally decomposed. However, the light-heat converter is added to the frit glass powder, the frit glass can be fabricated at a low temperature and a curing time of the frit glass can be significantly reduced.

The light-heat converter may be IR dye, carbon black, aluminum, or aluminum oxide, which converts light into heat.

The organic electro-luminescent diode E includes a first electrode **150**, a second electrode **170**, and an organic layer **160** interposed between the two electrodes **150** and **170**.

The first electrode **150** is formed of a transparent conductive material, e.g., indium tin oxide (ITO) and indium zinc oxide (IZO), etc. The second electrode **170** may be formed of a material, e.g., aluminum and aluminum alloy, which has a work function lower than that of the first electrode **150**.

In addition, the first substrate **100** includes a thin film transistor (TFT) Tr and the organic electro-luminescent diode E. The organic electro-luminescent diode E is electrically connected to the TFT Tr.

Specifically, the TFT Tr is electrically connected to the first electrode **150** of the organic electro-luminescent diode E. At this point, the first electrode **150** is patterned in each subpixel, and the second electrode **170** is electrically connected to the organic electro-luminescent diode E.

A moisture absorbent **210** may be provided inside the second substrate **200**. The moisture absorbent **210** removes residual moisture and oxygen from a sealed space between the first substrate **150** and the second substrate **170**.

FIGS. 2A to 2D are cross-sectional views illustrating a method for fabricating an organic electro-luminescence display device according to a first embodiment of the present invention.

Referring to FIG. 2A, a TFT Tr and an organic electro-luminescent diode E are formed on a first substrate **100**. The organic electro-luminescent diode E is electrically connected to the TFT Tr.

A buffer layer **110** is formed on the first substrate **100**. A semiconductor layer **105** is formed on the buffer layer **110**. The semiconductor layer **105** may be formed of polysilicon. A gate insulating layer **120** is formed over the first substrate **100** on which the semiconductor layer **105** is formed. A gate electrode **115** is formed above a portion of the gate insulating layer **120** corresponding to the semiconductor layer **105**.

A source region and a drain region are defined in the semiconductor layer **105** by implanting impurities into the semiconductor layer **105** using the gate electrode **115** as a mask.

An interlayer insulating layer **130** is formed over the gate electrode **115** and the gate insulating layer **110**. Source/drain electrodes **135a** and **135b** is formed on the interlayer insulating layer **130** to electrically connect to the source/drain regions of the semiconductor layer **105** through the interlayer insulating layer **130** and the gate insulating layer. In this way, the TFT Tr is formed on the first substrate **100**.

A passivation layer **140** is formed over the first substrate **100** where the TFT Tr is formed, and an organic electro-luminescent diode E is formed on the passivation layer **140**. The organic electro-luminescent diode E is electrically connected to the TFT Tr. The TFT Tr is electrically connected to a power line **155**.

The organic electro-luminescent diode E includes a first electrode **150** electrically connected to the TFT Tr. The first electrode **150** may be formed by depositing a transparent conductive material and patterning the deposited transparent conductive material in each subpixel. The first electrode **150** may be formed of ITO or IZO.

Insulating layer patterns **145** having an opening exposing the subpixel are formed on the first electrode **150**. The insulating layer patterns **145** may be formed of photoresist resin.

In each subpixel, an organic layer **160** is formed on the first electrode **150** exposed by the opening of the insulating layer patterns **145**. The organic layer **160** may include a hole injection layer, a hole transport layer, a hole blocking layer, an electron transport layer, and an electron injection layer so as to increase the luminous efficiency of the organic emission layer **160**.

A second electrode **170** is formed on the organic emission layer **160**. The second electrode **170** is used as a common electrode. The second electrode **170** may be formed of a conductive material having a work function less than that of the first electrode **150**. For example, the second electrode **170** may be formed of Al, Mg, or Ca. In this way, the organic electro-luminescent diode E electrically connected to the TFT Tr is formed.

Referring to FIG. 2B, a second substrate **200** is prepared. A moisture absorbent **210** may be provided in an inside of the second substrate **200** to absorb oxygen and moisture.

A preliminary sealant is coated on the periphery of the first substrate **100** or the second substrate **200**. The preliminary sealant includes a powder-type frit glass and a light-heat converter.

The light-heat converter converts light energy into heat energy and may be IR dye, carbon black, aluminum, or aluminum oxide.

Referring to FIG. 2C, the first substrate **100** and the second substrate **200** are attached to each other by the preliminary sealant. Then, the preliminary sealant is cured by selectively applying light energy and heat to thereby form a sealant **300**.

Specifically, the first substrate **100** and the second substrate **200** are attached to each other by the powder-type frit glass that is cured while being fused by the heat generated by the applied light energy and being cooled.

The light-heat converter uniformly mixed with the powder-type frit glass receives light energy to generate heat, whereby heat is uniformly supplied to the powder-type frit glass. Therefore, the curing time of the frit glass can be reduced and the heat can be uniformly supplied to the frit glass. Consequently, the frit glass is firmly cured, thereby reducing the moisture/air transmission rate.

The light energy may be provided through a laser or a beam heater. The laser or the beam heater selectively irradiates light energy onto the region where the sealant **300** is formed. Thus, heat is selectively transferred to the organic electro-luminescent diode E, thereby preventing the thermal decomposition of the organic electro-luminescent diode E.

The beam heater provides the sealant **300** with a beam having a wavelength of 0.1-200 μm at which the light-heat converter can be reacted. Since the beam heater irradiates a beam onto the sealant region in a line type or a rectangular type, the curing time of the sealant **300** can be reduced. Therefore, the time during which the organic electro-luminescent diode is exposed to the heat in the curing process of the sealant **300** is reduced, thereby preventing the thermal decomposition of the organic electro-luminescent diode E and the cracking of the first substrate **100** or the second substrate **200**.

Referring to FIG. 2D, the sealant **300** is formed by the fusing and recrystallization of the powder-type frit glass. Therefore, the sealant **300** can protect the organic electro-luminescent diode E from external moisture or oxygen. That is, the organic electro-luminescent diode E can be prevented from being degraded due to the moisture and/or oxygen

because the sealant **300** contains the frit glass having low moisture/oxygen transmission rate.

In addition, since the laser or the beam heater selectively irradiates light energy onto the region where the sealant **300** is formed, the organic electro-luminescent diode E can be prevented from being thermally decomposed by heat. Furthermore, The addition of the light-heat converter to the sealant **300** makes it possible to reduce the curing temperature and the curing time of the sealant **300** and cure the sealant **300** more firmly. Hence, the sealant **300** can perfectly block moisture and oxygen, thereby increasing the lifetime and reliability of the device.

FIG. 3 is a cross-sectional view of an organic electro-luminescence display device according to a second embodiment of the present invention. Since the organic electro-luminescence display device of FIG. 3 is similar to that of FIG. 1, except that a TFT and an organic electro-luminescent diode E are formed in the different substrates, a duplicate description will be omitted for conciseness.

Referring to FIG. 3, the organic electro-luminescence display device according to the second embodiment of the present invention includes first and second substrates **400** and **500** spaced apart from each other by a predetermined distance and attached to each other by a sealant **600**. A TFT Tr is formed on the first substrate **400**, and an organic electro-luminescent diode E is formed on the second substrate **500**.

Since it is difficult to separately form a moisture absorbent in such a dual panel type organic electro-luminescence display device, an encapsulation process of attaching the first substrate **400** to the second substrate **500** is required.

The sealant **600** includes a frit glass made using a light-heat converter. Since the sealant **600** having the frit glass has a moisture/oxygen transmission rate lower than that of a related art sealant, the lifetime and reliability of the organic electro-luminescent diode E can be significantly increased.

The light-heat converter may be IR dye, carbon black, aluminum, or aluminum oxide, which converts light energy into heat energy. The light-heat converter can reduce the temperature and time necessary to cure the sealant **600**. Therefore, the organic electro-luminescent diode E can be prevented from being thermally decomposed when the sealant **600** is cured.

Meanwhile, a plurality of gate lines and a plurality of data lines are crossed to one another over the first substrate **400**. The TFT Tr is disposed in a subpixel defined by the crossing of the two lines. The TFT Tr includes a gate electrode **401**, a semiconductor layer **402**, and source/drain electrodes **403a** and **403b**.

Characteristics of the TFT Tr can be improved by increasing a channel length of the TFT Tr, i.e., a length between the source electrode **403a** and the drain electrode **403b**.

A passivation layer **420** is formed over the first substrate **400** where the TFT Tr is formed. A connection electrode **404** is formed on the passivation layer **420** to contact the drain electrode **403b** of the TFT Tr. The TFT Tr is electrically connected to the organic electro-luminescent diode E through the connection electrode **404**. That is, the TFT Tr is electrically connected to a second electrode **530** of the organic electro-luminescent diode E.

A common voltage pad P is formed on the first substrate **400** to receive a common voltage from an external circuit and provide the received common voltage to the organic electro-luminescent diode E. The common voltage pad P includes a power electrode **411** and a power contact electrode **412**. The power electrode **411** is electrically connected to a common voltage line formed in the first substrate **400**, and the power contact electrode **412** is formed on the power electrode **411**

and electrically connected to a first electrode **510** of the organic electro-luminescent diode E.

A dummy pattern **413** is formed between the power electrode **411** and the power contact electrode **412**. The dummy pattern **413** has the same height difference as that of the TFT Tr.

An organic electro-luminescent diode E including a first electrode **510**, an organic emission layer **520**, and a second electrode **530** is formed under the second substrate **500**.

The first electrode **510** is formed under the second substrate **500**. The first electrode **510** acts as a common electrode and may be formed of a transparent conductive material, e.g., indium tin oxide (ITO) or indium zinc oxide (IZO).

An auxiliary electrode **505** may be further formed between the second substrate **500** and the first electrode **510**. The auxiliary electrode **505** reduces the resistance of the first electrode **510**. At this point, the auxiliary electrode **505** is formed of a low-resistance metal and is mostly opaque. Therefore, the auxiliary electrode **505** is preferably formed at a region corresponding to a non-emission region.

At least one of a hole injection layer (HIL), a hole transport layer (HTL), a hole blocking layer (HBL), an electron transport layer (ETL), and an electron injection layer (EIL) may be further formed under or above the organic emission layer **520**.

Therefore, electrons and holes can be more readily injected into the organic emission layer **520** because energy levels can be appropriately adjusted at boundaries of the first electrode **510**, the organic emission layer **520**, and the second electrode **530**. Hence, the luminous efficiency of the organic electro-luminescence display device can be significantly improved.

The second electrode **530** is formed to surround the periphery of a first spacer **535a** that constantly maintains a cell gap between the first substrate **400** and the second substrate **500**. Due to the first spacer **535a**, a portion of the second electrode **530** protrudes toward the first substrate **400**. The protruding second electrode **530** contacts the connection electrode **404**. In addition, the second electrode **530** is automatically patterned in each subpixel by a separator **425** disposed on a buffer layer **415** formed in the periphery of the subpixel.

The organic electro-luminescence display device further includes a second spacer **535b** having the same height as the first spacer **535a**. The second spacer **535b** is formed in a region corresponding to the region where the power contact electrode **412** is formed. At this point, a second electrode dummy pattern **540** separated from the second electrode **530** is formed to surround the second spacer **535b**. The second electrode dummy pattern **540** surrounding the second spacer **535b** contacts the power contact electrode **412**. The second electrode dummy pattern **540** separated from the second electrode **530** is electrically connected to the first electrode **510**. The first electrode **510** and the power contact electrode **412** are electrically connected by the second spacer **535b**, so that the common voltage can be applied to the first electrode **510**.

FIGS. 4A to 4D are cross-sectional views illustrating a method for fabricating a method for fabricating an organic electro-luminescence display device according to a second embodiment of the present invention.

Referring to FIG. 4A, a first substrate **400** is prepared, and a TFT Tr is formed on the first substrate **400**.

Specifically, a conductive layer is formed on the first substrate **400** and is patterned to form a gate line (not shown) and a gate electrode **401**. At this point, the gate line is formed in one direction and the gate electrode **401** is branched from the gate line. Simultaneously, a power electrode **411** may be formed such that it receives a common voltage from an external signal and applies the received common voltage to an organic electro-luminescent diode, which will be described

later. In addition, a first dummy pattern **413a** is formed spaced apart from the power electrode **411** by a predetermined distance.

A gate insulating layer **410** is formed over the first substrate **400** where the gate electrode **401** is formed. The gate insulating layer **410** may be formed using a silicon oxide layer, a silicon nitride layer, or a stacked layer thereof, which is deposited by a chemical vapor deposition (CVD) process.

A semiconductor layer **402** corresponding to the gate electrode **401** is formed on the gate insulating layer **410**. Simultaneously, a second dummy pattern **413b** corresponding to the first dummy pattern **413a** may be further formed on the gate insulating layer **410**.

A first conductive layer (not shown) is formed on the semiconductor layer **402** and the gate insulating layer **410** and is patterned to form a data line (not shown) crossing the gate line (not shown). Simultaneously, a drain electrode **403b** is formed on a center portion of the semiconductor layer **402**, and a source electrode **403a** is formed in an annular shape to surround the periphery of the drain electrode **403b**. Therefore, characteristics of a TFT Tr can be improved by increasing a channel region of the TFT Tr, i.e., an area corresponding to the source electrode **403a** and the drain electrode **403b**. In addition, a third dummy pattern **413c** may be further formed on the second dummy pattern **413b**.

In this way, the TFT Tr including the gate electrode **401**, the semiconductor layer **402** and the source/drain electrodes **403a** and **403b** is formed.

A passivation layer **420** is formed on the gate insulating layer **410** and the TFT Tr. The passivation layer **420** may be formed using an organic layer or an inorganic layer. For example, the organic layer may be acryl-based resin, benzocyclo-butene (BCB), polyimide (PI), or Novolac resin, and the inorganic layer may be a silicon oxide layer, a silicon nitride layer, or a stacked layer thereof.

Contact holes are formed in the passivation layer **420** to expose portions of the drain electrode **403b** and the power electrode **411**.

A conductive layer is formed on the passivation layer **420** with the contact holes and is patterned to form a connection electrode **404** electrically connected to the drain electrode **403b**. Simultaneously, a power contact electrode **412** may be formed. The power contact electrode **412** is disposed on the first to third dummy patterns **413a**, **413b** and **413c**, such that it has the same height difference as that of the connection electrode **404**.

Referring to FIG. 4B, a second substrate **500** where an organic electro-luminescent diode E is formed is prepared.

Specifically, the second substrate **500** is prepared, and a first electrode **510** is formed as a common electrode on the second substrate **500**. The first electrode **510** is formed of a transparent conductive material having a high work function. For example, the first electrode **510** may be formed of ITO or IZO.

A buffer layer **515** is formed to define pixel regions on the first electrode **510**. The buffer layer **515** is formed of an insulating layer. A separator **525** is formed on the buffer layer **515**. The separator **525** may be formed in a shape of a reversely tapered partition wall. The separator **525** may be formed of an organic insulating material. In addition, an island-shaped buffer layer **515** is further formed in the subpixel, and a first spacer **535a** is formed on the buffer layer **515**. Simultaneously, a second separator **535b** is formed to have the same height as that of the first spacer **535a**.

An organic emission layer **520** and a second electrode **530** are sequentially formed over the first spacer **535a** and the first electrode **510**. The second electrode **530** is automatically

separated in each subpixel by the separator **525**. In addition, because the second electrode **530** extends over the first spacer **535a**, a portion of the second electrode **530** protrudes upwards due to the first spacer **535a**. At the same time, a second electrode dummy pattern **540** separated from the second electrode **530** is formed to surround the second spacer **535b**. The second electrode dummy pattern **540** also protrudes upwards. The second electrode dummy pattern **540** is electrically connected to the first electrode **510**.

Before forming the organic emission layer **520**, a hole injection layer and/or a hole transport layer may be further formed. In addition, after forming the organic emission layer **520**, at least one of a hole blocking layer, an electrode transport layer and an electrode injection layer may be further formed.

Referring to FIG. 4C, a sealant **600** is coated on the first substrate **400** where the TFT Tr is formed or the second substrate **500** where the organic electro-luminescent diode E is formed. The sealant **600** contains a frit glass and a light-heat converter. The light-heat converter may be at least one of IR dye, carbon black, aluminum, or aluminum oxide, which converts light energy into heat energy.

Then, the first and second substrates **400** and **500** are aligned such that the TFT Tr and the common voltage pad P formed in the first substrate **400** electrically contact the organic electro-luminescent diode E. That is, the connection electrode **404** contacts the second electrode **530** protruded by the first spacer **535a**. In addition, the power contact electrode **412** corresponding to the dummy pattern **413** electrically contacts the second electrode dummy pattern **540** protruded by the second spacer **535b**.

The sealant **600** is cured by irradiating light energy onto the region where the sealant **600** is formed, and the first substrate **400** and the second substrate **500** are attached to each other such that the organic electro-luminescent diode is sealed.

A laser or a beam heater may be used to provide light energy only to the region where the sealant **600** is formed. The beam heater may have a wavelength ranging from about 0.1 μm to about 200 μm .

In this way, the first substrate **400** and the second substrate **500** are attached to each other using the frit glass having low moisture/oxygen transmission rate. Since the light-heat converter is added to the sealant **600**, the curing time and the curing temperature of the frit glass can be reduced. Moreover, the curing degree of the frit glass can be increased, thereby further reducing the moisture or oxygen transmission rate.

Therefore, the lifetime and reliability of the organic electro-luminescence display device can be increased by preventing the degradation of the organic electro-luminescence display device and protecting against external oxygen or moisture.

When the substrate where the TFT and the organic electro-luminescent diode are formed is attached to a separate encapsulation substrate, the yield of the organic electro-luminescence display device is determined by the product of the yield of the TFT and the yield of the organic electro-luminescent diode. Therefore, the total yield is greatly dependent on the process of forming the organic electro-luminescent diode, which is performed at a later stage. However, the second embodiment of the present invention can expect the reduced deflection rate and the increased production yield by forming the TFT and the organic electro-luminescent diode on the different substrates and attaching the two substrates.

As described above, the lifetime and reliability of the organic electro-luminescence display device can be increased by performing the encapsulation process using the frit glass having low moisture/oxygen transmission rate.

In addition, since the light-heat converter is added to the frit glass, the curing temperature and the curing time can be reduced, thereby preventing the degradation of the organic electro-luminescence display device.

Furthermore, since the light energy is irradiated only onto the region where the sealant is formed, the organic electro-luminescent diode can be prevented from being degraded due to heat transferred thereto.

It will be apparent to those skilled in the art that various modifications and variations can be made in the present invention. Thus, it is intended that the present invention covers the modifications and variations of this invention provided they come within the scope of the appended claims and their equivalents.

What is claimed is:

1. An organic electro-luminescence display device comprising:

- a first substrate;
- a second substrate opposite to the first substrate;
- a display element disposed on the first substrate;
- a moisture absorbent formed on the second substrate;
- a thin film transistor disposed on the first substrate and under the moisture absorbent; and

a sealant formed adjacent the periphery of the first substrate and of the second substrate, wherein the sealant includes a mixture of a powder-type frit glass and at least one of IR dye and carbon black,

wherein the frit glass is disposed between the first substrate and the second substrate and is cured by heat generated by the at least one of the IR dye and the carbon black, wherein the at least one of the IR dye and the carbon black is uniformly mixed with the powder-type frit glass in the sealant and receives and converts a light energy to heat energy and uniformly supplies the heat energy to the frit glass, thereby reducing a curing time of the frit glass; wherein the moisture absorbent removes residual moisture and oxygen from a sealed space between the first substrate and the second substrate,

wherein the display element comprises first and second electrodes disposed on the first substrate and having different work functions, an organic layer disposed between the first electrode and the second electrode and having an organic emission layer, and insulating layer patterns having an opening exposing the sub-pixel and disposed on the first electrode,

wherein the insulating layer patterns are formed of photo-resist resin.

2. The organic electro-luminescence display device according to claim 1, wherein the first electrode is formed by depositing a transparent conductive material and patterned the deposited transparent conductive material in each sub-pixel.

3. The organic electro-luminescence display device according to claim 1, wherein at least two first electrodes are provided on the first substrate in a matrix form.

4. A method for fabricating an organic electro-luminescence display device, comprising:

- preparing a first substrate;
- forming a display element on the first substrate;
- preparing a second substrate;
- forming a moisture absorbent on the second substrate;
- forming a thin film transistor on the first substrate and under the moisture absorbent;

uniformly mixing a powder-type frit glass with at least one of IR dye and carbon black to form a mixture of the powder-type frit glass and the at least one of IR dye and the carbon black;

11

coating the mixture of the powder-type frit glass and the at least one of the IR dye and the carbon black in a periphery of the first or second substrate;

attaching the first substrate to the second substrate;

irradiating light energy to the mixture of the powder-type frit glass and the at least one of the IR dye and the carbon black such that the at least one of the IR dye and the carbon black converts the light energy into heat energy; curing the powder-type frit glass by using the heat energy generated by the at least one of IR dye and carbon black; wherein the moisture absorbent removes residual moisture and oxygen from a sealed space between the first substrate and the second substrate;

wherein the display element comprises first and second electrodes disposed on one of the first and second substrates having different work functions and an organic layer disposed between the first electrode and the second electrode and having an organic emission layer.

5. The method according to claim 4, wherein the display element is formed on the first substrate, the display element further comprises insulating layer patterns having an opening exposing the sub-pixel and disposed on the first electrode connected to the thin film transistor.

12

6. The method according to claim 4, wherein the at least one of the IR dye and the carbon black is uniformly mixed with the powder-type frit glass in the sealant and uniformly supplies the heat energy to the frit glass, thereby reducing a curing temperature of the frit glass.

7. The method according to claim 4, wherein the first substrate and the second substrate are attached to each other by the powder-type frit glass that is cured while being fused by the heat generated by the applied light energy and being cooled.

8. The method according to claim 4, wherein the light energy is provided only to the mixture of the powder-type frit glass and the at least one of the IR dye and the carbon black.

9. The method according to claim 8, wherein the light energy is provided only to the mixture of the powder-type frit glass and the at least one of the IR dye and the carbon black, thereby avoiding the display element thermally decomposed.

10. The method according to claim 8, wherein a beam heater is used to provide light energy only to the region where the mixture of the powder-type frit glass and the at least one of the IR dye and the carbon black is formed, and

wherein the beam heater is a line type or a rectangular type.

* * * * *

专利名称(译)	有机电致发光显示装置及其制造方法		
公开(公告)号	US8736163	公开(公告)日	2014-05-27
申请号	US11/824001	申请日	2007-06-28
[标]申请(专利权)人(译)	乐金显示有限公司		
申请(专利权)人(译)	LG 飞利浦LCD CO. , LTD.		
当前申请(专利权)人(译)	LG DISPLAY CO. , LTD.		
[标]发明人	KIM JEONG HYUN YOO CHOONG KEUN CHO HEUNG LYUL LEE JOON SUK MOON JONG SEOK YOO IN SUN		
发明人	KIM, JEONG HYUN YOO, CHOONG KEUN CHO, HEUNG LYUL LEE, JOON SUK MOON, JONG SEOK YOO, IN SUN		
IPC分类号	H01L51/52 H01L51/56		
CPC分类号	H01L27/3251 H01L51/5259 H01L51/5246		
优先权	1020060061211 2006-06-30 KR		
其他公开文献	US20080001533A1		
外部链接	Espacenet USPTO		

摘要(译)

提供了一种有机电致发光显示装置及其制造方法。第一基板和第二基板通过密封剂密封。在第一基板上形成有机电致发光二极管。密封剂包含熔结玻璃和光热转换器。熔结玻璃可以通过防止有机电致发光二极管在固化过程中热分解而降低湿气和氧气的透过率。由于两个衬底由熔结玻璃封装，可以提高有机电致发光显示装置的使用寿命和可靠性。

